



MEASUREMENT AND CONTROL

SEE MORE AT SORInc.com

Request Quote

Temperature Switches

The **SOR® temperature switch** utilizes a vapor-pressure thermal system. Fluid vapor pressure changes predictably according to the influence of temperature on the sensing bulb. Process temperature changes cause proportional vapor pressure changes in the temperature sensing bulb that act on the diaphragm/piston assembly to actuate and deactivate a snap-action electrical switching element at discrete process temperatures. The instrument's behavior is determined by the vapor pressure principle.

Application Information

Basic models with direct and six-foot remote temperature bulbs can be specified from the quick selection guide on page 5.

More specific application requirements can be met by selecting optional components, such as housings and electrical switching elements, from the balance of the catalog.

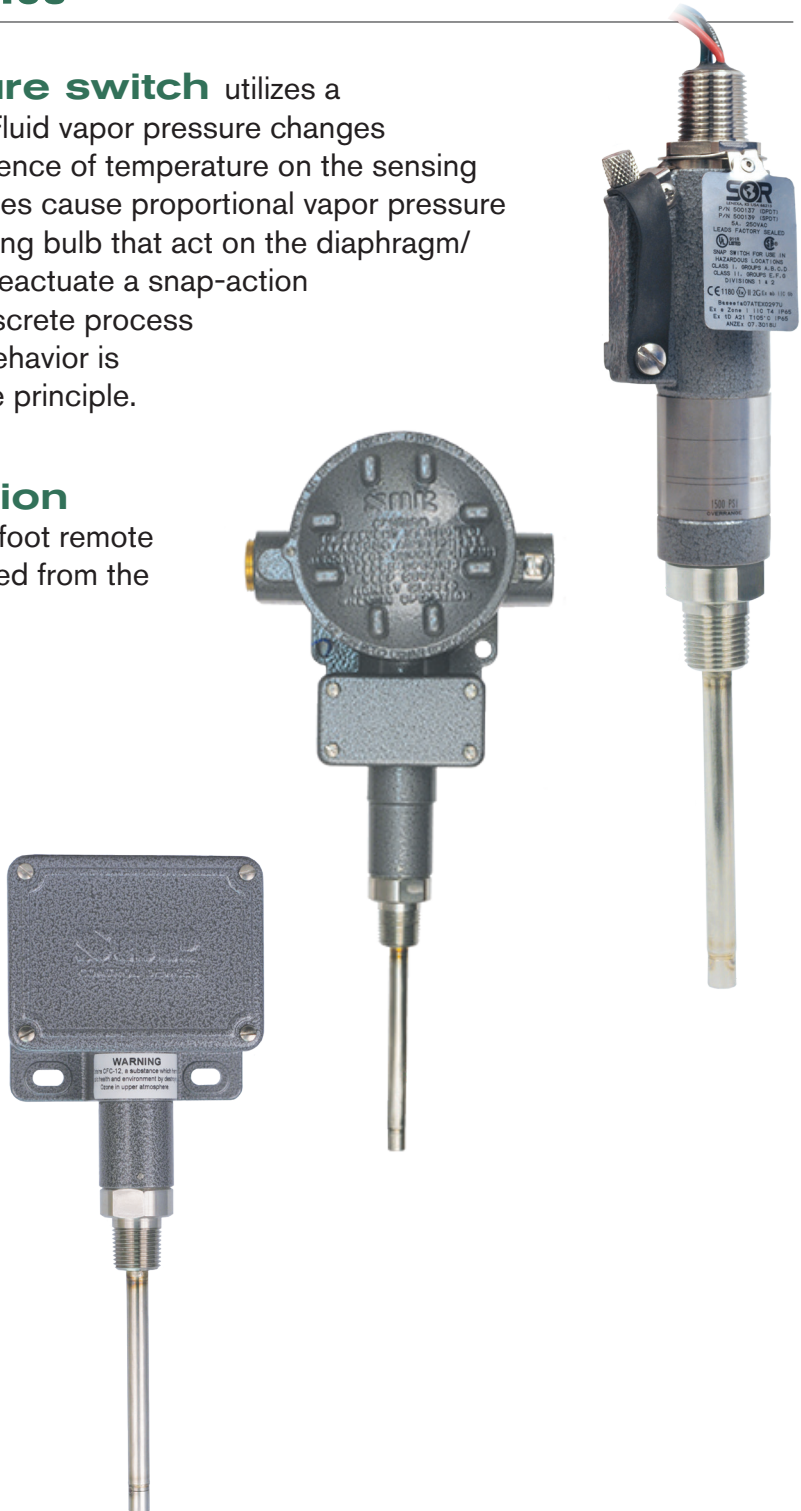

Robust Construction

- Rugged, high-cycle rate tolerance, long life, not critical to vibration, high overrange and proof pressures, excellent corrosion resistance to hostile environments.
- Enclosure ratings: NEMA 1, 4, 4X, 7, or 9 available.
- Ingress protection rating up to IP66.

Vapor Pressure Principle

- Device's behavior is predictable and in accordance with the vapor pressure principle.
- Minimal ambient temperature influence, fast response, high repeatability, narrow dead band.

Vapor Fill Fluid

- Excellent chemical and thermal stability, predictable temperature-vapor pressure curve, nonflammable, low toxicity.

Direct Immersion Temperature Sensing Bulbs

- 316SS can withstand 2300 psig (1000 psig on 105 range) without thermowell, faster response time, lower cost.

Remote Mount Sensing Bulbs

- 316SS capillary tube with 300 Series SS armor allows instrument to be panel mounted and bulb to be remotely located.
- Standard 300 Series SS armor protects capillary.

Snap-Action Electrical Switching Element

- Long life, high load capacity, high ambient temperature limit, insensitive to vibration, SPDT or DPDT switching action, optional "hermetically sealed" capsule for hazardous locations and hostile environments.

Shock/Vibration

- Select models tested to MIL-S-901D (Navy) shock test.
- Select models tested to MIL-S-167 vibration test.

Factory Calibration

- **FREE!** Calibrated to customer's set point, ready to install.

Agency Listings/Certification

- Select models with ATEX, IECEx, CSA, INMETRO, TestSafe, UL
- Meets most code and customer requirements.

Safety Certified to IEC 61508 (SIL)

- SOR products are certified to IEC 61508 for non-redundant use in SIL1 and SIL2 Safety Instrumented Systems for most models. For more details or values applicable to a specific product, see the Safety Integrity Level Quick Guide (Form 1528).

Warranty

- 3 years from the date of manufacture.

How the SOR Temperature Switch Works

The SOR temperature switch consists of a pressure switch that has a sealed temperature sensing bulb attached directly to the pressure port. (An optional remote temperature sensing bulb can be connected to the pressure port with an armor-clad capillary.) The temperature sensing system is partially filled with a fluid. Process temperature changes cause proportional vapor pressure changes in the temperature sensing bulb that act on the diaphragm/piston assembly to actuate and deactuate a snap-action electrical switching element at discrete process temperatures. The instrument's behavior is determined by the vapor pressure principle. (The 105 range unit is similar, except the fill fluid is inert gas.)

Dual (HI-LO)

SOR temperature switches in this catalog may be specified with two set points. The two set points may be set at either the same actuation point or split up to full scale with no interaction between set points. The Dual HI-LO is available with hermetically sealed, explosion proof, UL Listed and CSA Certified electrical switching elements or with a wide selection of UL Listed and CSA Certified snap-action switching elements for both AC and DC service. The housing selection must be V1 or V2. See page 9.

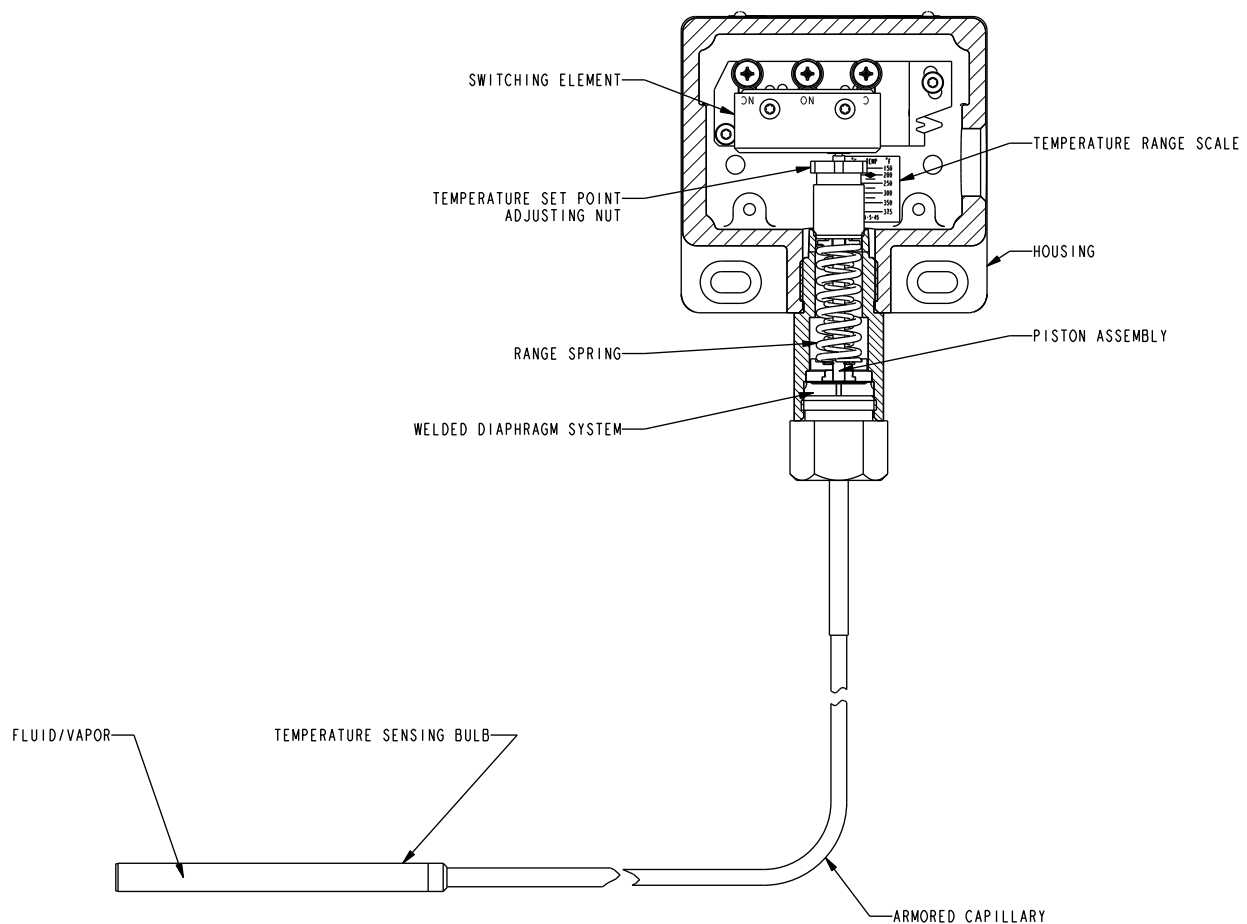

Drawing 0190316

Application Information

SOR temperature switches in this catalog are suitable for a wide variety of process and fluid power applications. Specific application requirements can normally be met by selecting optional components, such as switching elements. Certain applications may require customized specials. Consult area representative or the factory.

Weatherproof, conventional explosion-proof and hermetically sealed, explosion proof models are presented in this catalog.

Quick Selection Guide

Basic SOR temperature switches with standard parts are normally suitable for a variety of industrial applications.

- Refer to the **Quick Selection Guide** section on page 4 for a basic model number. Corrosive service and particular customer requirements may require optional components.
- Refer to the **Engineered to Order Model Tree** section below to build a customized model number with optional components, such as: switching elements, diaphragm systems, pressure ports and accessories.

Engineered to Order Model Tree

Use to configure and order a customized product for your application.

- You must select a designator for each component except Accessories.
- Reference tables, charts and additional information is provided throughout the catalog to help you make your selections. See pages noted in the tree.

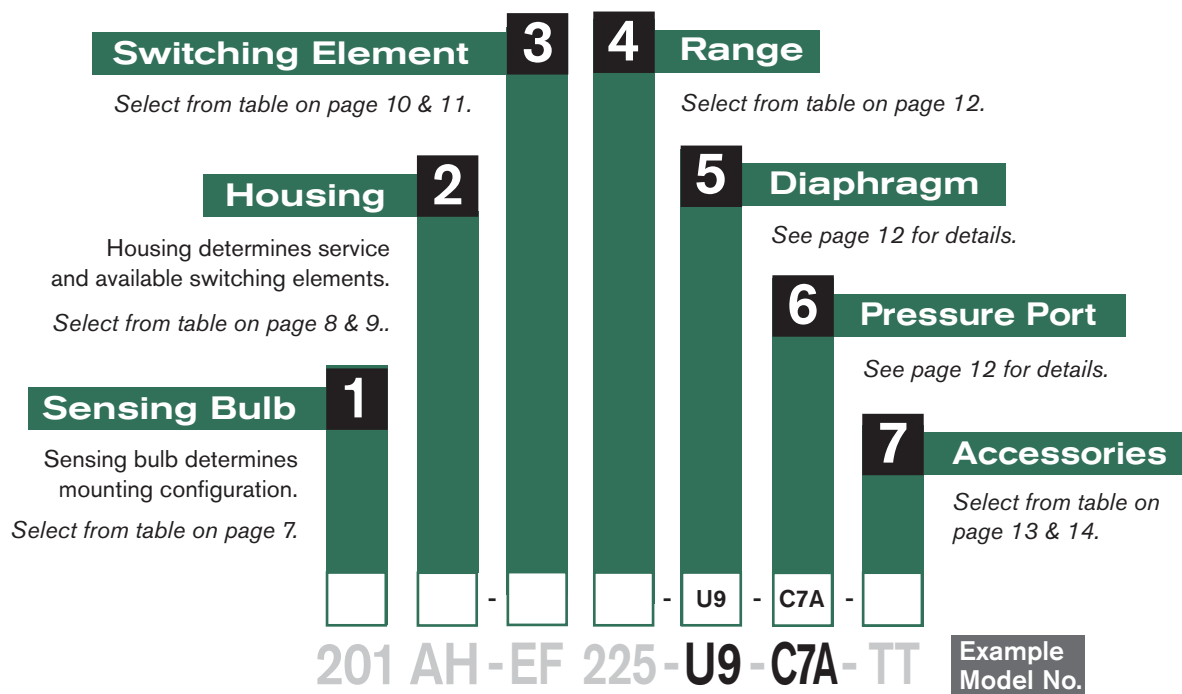

Note

1. If thermowell is required, select from table on page 14 and order as a separate item.
2. If Agency Approved, Certified or Listed temperature switches are required, see page 15 for components that must be specified.

Temperature Switches

Quick Selection Guide



Weatherproof-NEMA 4, 4X, IP66
(Direct Mount Shown)



Explosion Proof-Conventional
(Direct Mount Shown)



Explosion Proof-Hermetically Sealed
(Direct Mount Shown)

Weatherproof, NEMA 4, 4X, IP66	Explosion Proof Class I, Groups C & D; Class II, Groups E, F & G; Divisions 1 & 2	Contains Hermetically Sealed Explosion-Proof Switching Element Class I, Groups A, B, C & D; Class II, Groups E, F & G; Divisions 1 & 2
--------------------------------	--	---

Direct Mount Temperature Switches

SPDT Form "C" Contacts

Maximum Process Pressure 2300 psi

Adjustable Range	Overrange Temperature	Electrical Rating @250VAC	Typical Dead Band		Model Number			
150 to 350°F 66 to 177°C	500°F 260°C	15 amps	2.2°F	1.2°C	201NN-K215-U9-C7A	●		
					201L-K215-U9-C7A		●	
50 to 200°F 10 to 93°C	340°F 171°C	15 amps	6.6°F	3.7°C	201AH-EF215-U9-C7A			●
					201NN-K225-U9-C7A	●		
-60 to 60°F -51 to 15°C	170°F 77°C	15 amps	1.2°F	0.7°C	201L-K225-U9-C7A		●	
					201AH-EF225-U9-C7A			●
-60 to 60°F -51 to 15°C	170°F 77°C	15 amps	1.4°F	0.8°C	201NN-K235-U9-C7A	●		
					201L-K235-U9-C7A		●	
-60 to 60°F -51 to 15°C	170°F 77°C	5 amps	4.2°F	2.3°C	201AH-EF235-U9-C7A			●

Remote Mount Temperature Switches with 6' Capillary

(not shown)

SPDT Form "C" Contacts

Maximum Process Pressure 2300 psi

Adjustable Range	Overrange Temperature	Electrical Rating @250VAC	Typical Dead Band		Model Number			
150 to 350°F 66 to 177°C	500°F 260°C	15 amps	2.2°F	1.2°C	203NN-K215-U9-C7A	●		
					203L-K215-U9-C7A		●	
50 to 200°F 10 to 93°C	340°F 171°C	15 amps	3.3°F	1.8°C	203BA-KB215-U9-C7A			●
					203NN-K225-U9-C7A	●		
-60 to 60°F -51 to 15°C	170°F 77°C	15 amps	1.2°F	0.7°C	203L-K225-U9-C7A		●	
					203BA-KB225-U9-C7A			●
-60 to 60°F -51 to 15°C	170°F 77°C	15 amps	1.4°F	0.8°C	203NN-K235-U9-C7A	●		
					203L-K235-U9-C7A		●	
-60 to 60°F -51 to 15°C	170°F 77°C	5 amps	2.1°F	1.2°C	203BA-KB235-U9-C7A			●

Design and specifications are subject to change without notice. For latest revision, see sorinc.com.

SOR recognizes that there is not an industry convention with respect to terminology and definitions pertinent to temperature switches. The following list applies to SOR Temperature Switches.

Temperature Switch

A bi-stable electromechanical device that actuates/deactuates one or more electrical switching element(s) at a predetermined discrete temperature (set point) upon rising or falling temperature.

Adjustable Range

The span of temperature between upper and lower limits within which the temperature switch can be adjusted to actuate/deactuate. It is expressed for increasing temperature.

Set Point

That discrete temperature at which the temperature switch is adjusted to actuate/deactuate on rising or falling temperature. It must fall within the adjustable range and be called out as increasing or decreasing temperature.

Dead Band

The difference in temperature between the increasing set point and decreasing set point. It is expressed as "typical," which is an average with the increasing set point at mid-adjustable range with the standard K switch element. It is normally fixed (not adjustable).

Hermetically Sealed

A welded steel capsule with glass-to-metal, factory-sealed electrical leads that isolates the electrical switching element(s) from the environment.

Overrange

Overrange temperature is that temperature to which the sensing bulb can be continuously exposed without causing permanent change of set point or distortion sufficient to cause leakage or significant degradation of the fill fluid. Temperatures greater than overrange could cause permanent damage and render the device inoperative.

Maximum Process Pressure

The maximum process pressure to which the temperature sensing bulb should be exposed without being protected by a thermowell.

Repeatability

The ability of a temperature switch to successively operate at a set point that is approached from a starting point in the same direction and returns to the starting point over consecutive cycles to establish a temperature profile. The closeness of the measured set point values is normally expressed as percentage of full scale (maximum adjustable range temperature.)

Repeatability is 1% of full scale for ranges 235, 225 and 215. Range 105 has a repeatability of 2% of full scale.

SPDT Switching Element

Single-Pole, Double-Throw (SPDT) has three connections: C-Common, NO-Normally Open and NC-Normally Closed, which allows the switch to be electrically connected to the circuit in either NO or NC state.

DPDT Switching Element

DPDT is two synchronized SPDT switching elements which actuate together at increasing set point and deactuate together at decreasing set point. Discrete SPDT switching elements allow two independent circuits to be switched; i.e., one AC and one DC.

The synchronization linkage is factory set, and is not field adjustable. Synchronization is verified by connecting test lamps to the switching elements and observing them go "On" simultaneously at actuation and "Off" simultaneously at deactuation.

Temperature Switches

Step 1: Sensing Bulb

201AH-EF225-U9-C7A-TT

Temperature Bulb Type

Designator	Mounting Configuration	Capillary Length		Process Connection
		feet	meters	
201	Direct	-	-	1/2" NPT(M)
203	Remote	6.0	1.8	
205		10.0	3.0	
207		15.0	4.5	
209		20.0	6.0	

Notes



1. For applications where a special length capillary system is required, contact the factory or your local representative for specifications and delivery.
2. Special bulb dimensions are available. Contact the factory for details.

Temperature Switches









Step 2: Housing

201AH-EF225-U9-C7A-TT







General Purpose NEMA 1

 <p>PP</p> <p>Electrical: 3/4" NPT(F) - Right Material: Aluminum See Agency Listings page 15 See Switching Element Groups 1, 2, 3 & 4 on page 10.</p>	 <p>P3</p> <p>Electrical: 3/4" NPT(F) - Left, Right Material: Aluminum See Switching Element Groups 1, 2, 3 & 4 on page 10.</p>
---	---

Weatherproof - NEMA 4, 4X, IP66

 <p>NN</p> <p>Electrical: 3/4" NPT(F) - Right Material: Aluminum See Agency Listings page 15 See Switching Element Groups 1, 2, 3 & 4 on page 10.</p>	 <p>N3</p> <p>Electrical: 3/4" NPT(F) - Left, Right Material: Aluminum See Agency Listings page 15 See Switching Element Groups 1, 2, 3 & 4 on page 10.</p>	 <p>N4</p> <p>Electrical: 3/4" NPT(F) - Right Material: Aluminum Cover: Heavy Duty with Viton gasket See Switching Element Groups 1, 2, 3 & 4 on page 10.</p>
 <p>N6</p> <p>Electrical: 3/4" NPT(F) - Right Material: Carbon Steel See Switching Element Groups 1 & 3 on page 10.</p>	 <p>RN RM</p> <p>Electrical- RN: 3/4" NPT(F) - Right Electrical- RM: M20 x 1.5-Right Standard terminal block Material: Aluminum See Agency Listings page 15 See Switching Element Groups 1, 2, 3 & 5 on page 10.</p>	 <p>RT RS</p> <p>Electrical- RT: 3/4" NPT(F) - Right Electrical- RS: M20 x 1.5 - Right Standard terminal block Material: 316SS See Agency Listings page 15 See Switching Element Groups 1, 2, 3 & 5 on page 10.</p>
 <p>*V1</p> <p>Electrical: 3/4" NPT(F) - Top Standard terminal block Material: Aluminum See Agency Listings page 15 See Switching Element Groups 1, 3 & 4 on page 10.</p>	 <p>AC</p> <p>Electrical: 90° conduit block 1/2" NPT(M) 18" free wire leads Material: Series 2000 Aluminum Switching Element AD only.</p>	 <p>RB</p> <p>Electrical: 3/4" NPT(F) - Right Manual reset only Standard terminal block Material: Aluminum See Agency Listings page 15 See Switching Element Group 7 on page 10.</p>

Hazardous Locations - Hermetically Sealed Switching Element NEMA 4, 4X, 7, 9, IP66

 <p>AG</p> <p>Contains UL Listed and CSA Certified hermetically sealed switching element. Electrical: 1/2" NPT(M) - Top Material: Copper-free** aluminum See Switching Element Group 5 on page 10.</p>	 <p>BG</p> <p>ATEX/IECEX Certified (Ex db IIC T6/T5 Gb) Electrical: 1/2" NPT(M) - Top Material: Copper-free** aluminum See Agency Listings page 15 See Switching Element Group 5 on page 10.</p>	 <p>*V2</p> <p>Contains UL Listed and CSA Certified hermetically sealed switching elements. Electrical: 3/4" NPT(F) - Top Material: Aluminum See Switching Element Group 5 on page 10.</p>
 <p>AH</p> <p>Contains UL Listed and CSA Certified hermetically sealed switching element. Electrical: 1/2" NPT(M) - Top Material: 316SS See Switching Element Group 5 on page 10.</p>	 <p>BH</p> <p>ATEX/IECEX Certified (Ex db IIC T6/T5 Gb) Electrical: 1/2" NPT(M) - Top Material: 316SS See Agency Listings page 15 See Switching Element Group 5 on page 10.</p>	 <p>*BA</p> <p>Contains UL Listed and CSA Certified hermetically sealed switching elements. Electrical: 3/4" NPT(F) - Top Material: Copper-free** aluminum Weatherproof: NEMA 4/4X See Switching Element Group 6 on page 10.</p>

* Not recommended for direct mount where vibration is expected. Housing should be securely mounted to a flat surface (bulkhead or panel rack) or pipe stanchion.







** Consult the factory.

Temperature Switches

Step 2: Housing

201AH-EF225-U9-C7A-TT

Hazardous Locations - Conventional Explosion Proof NEMA 4, 4X, 7, 9, IP66

 <p>*L UL Listed Class I, Groups C & D; Class II, Groups E, F & G; Divisions 1 & 2 as an outlet box only Electrical: 3/4" NPT(F) - Right Material: Cast Iron Weatherproof with Option CG See Switching Element Groups 1 & 3 below.</p>	 <p>*LC UL Listed Class I, Groups C & D; Class II, Groups E, F & G; Divisions 1 & 2 as an outlet box only Electrical: 3/4" NPT(F) - Right Material: Copper-free**aluminum Weatherproof See Switching Element Groups 1, 2, 3 & 4 below.</p>	 <p>Separate electrical and set point adjustment compartments Weatherproof Standard terminal block See agency listings on page 15.</p>
 <p>*S UL Listed Class I, Groups C & D; Class II, Groups E, F, & G; Divisions 1 & 2 as an outlet box only Electrical: 3/4" NPT(F) - Left, Right, Top Material: Cast Iron Weatherproof with Option CG See Switching Element Groups 1, 3, & 7 below.</p>	 <p>*SC UL Listed Class I, Groups C & D; Class II, Groups E, F & G; Divisions 1 & 2 as an outlet box only Electrical: 3/4" NPT(F) - Left, Right, Top Material: Copper-free**aluminum Weatherproof See Switching Element Groups 1, 2, 3, 4 & 7 below.</p>	<p>*B3 Electrical: 3/4" NPT(F) - Left, Right Material: Aluminum</p> <p>*B4 Electrical: M20 x 1.5 - Left, Right Material: Aluminum</p>
 <p>*TA Class 1, Groups A, B, C, D; Class II, Groups E, F, & G; Divisions 1 & 2 as an outlet box only Electrical 3/4" NPT(F) - Left, Right, Top Material (Housing): Aluminum Material (Cover): Aluminum Line Mounted. Weatherproof with Option CG. See Switching Element Groups 1 & 3 below.</p>		<p>*B5 Electrical: M20 x 1.5 - Left, Right Material: Cast Iron</p> <p>*B6 Electrical: 3/4" NPT(F) - Left, Right Material: Cast Iron</p> <p>Switching Element Groups 1, 2, 3, 4 & 5 below.</p>

* Not recommended for direct mount where vibration is expected. Housing should be securely mounted to a flat surface (bulkhead or panel rack) or pipe stanchion.

** Consult the factory.

Switching Element Group / Housing Compatibility

Group 1	Group 2	Group 3	Group 4	Group 5	Group 6	Group 7
A, AA, B, BB, BD*, C**, E, EE, G, J, JJ, K, KA, L, W, Y	GG, KK, LL, YY	T	H	AF, AG, EF, EG, JF, JG	EB, JB, JR, KB	D, M

*BD only available with RN, RM, RT and RS housings

**C micro switch is not available in L, S and TA housings

Temperature Switches

Step 3: Switching Element

201AH-**EF**225-U9-C7A-TT

Cross reference compatibility chart on page 10 to ensure that switching element will fit in housing.

Switching Element Service	Electrical Contact Type	Electrical Connection Type	AC Rating		DC Rating Resistive				Dead Band Multiplier		Designator	
			Volts	Amps	Volts	Amps	Volts	Amps	SPDT	DPDT	SPDT	DPDT
Normal Service AC	Single Switching Element SPDT - (1) SPDT Double Switching Element DPDT -(2) SPDT Synchronized actuation/deactuation at increasing/decreasing Set Points	K, KA, G, L, C, N, Y, W Switching Elements - Screw Terminals. All other Switching Elements - 18" 18 AWG Color-Coded Wire Leads except when terminal blocks are specified. T & H Switching Elements - Consult the factory.	250	15	125	0.4*	30	5.0*	1.0	6.0	K	KK
Low Power Gold Contacts			125	1	-	-	28	1.0*	1.0	-	KA	N/A
Wide Dead Band AC			125	1	-	-	30	1.0	1.5	5.0	J	JJ
AC or DC			250	15	125	0.5	-	-	3.0	6.0	G	GG
Wide Dead Band DC			250	11	125	0.5*	30	5.0	3.0	6.0	A	AA
Narrow Dead Band DC			250	15	125	0.5	30	10.0*	3.5	6.5	L	LL
Hi-Ambient Temperature Rating - 400°F			250	5	125	0.5*	30	5.0*	1.5	4.0	E	EE
Potted Wire Leads 1/2" NPT(M) Condition Connection			250	5	125	0.3	-	-	3.0	6.0	B	BB
Wide Adjustable Dead Band			250	5	125	0.5*	-	-	1.5	3.5	Y	YY
Narrow Adjustable Dead Band			250	5	125	0.3	-	-	1.0	-	W	N/A
Manual Reset - Decreasing Temperature (Automatic Actuation-Increasing Temperature)			250	11	125	0.5*	30	5.0	3.0	-	AD	N/A
Manual Reset - Increasing Temperature (Automatic Actuation-Decreasing Temperature)			250	15	125	0.4*	-	-	2.5 to 6.5	-	T	N/A
Corrosion Resistant Explosion-Proof Hermetically Sealed Switching Element			250	15	-	-	-	-	1 to 3	-	H	N/A
Corrosion Resistant, Explosion Proof, Lower-Power Service Hermetically Sealed Gold Contacts			250	15	125	0.5	-	-	1.5	-	D	N/A
Explosion-Proof EEx d IIC T6			250	15	125	0.5	-	-	1.5	-	M	N/A
			250	15	125	0.4*	30	5.0*	1.5	-	KB	N/A
			250	5	125	0.5*	30	5.0*	-	5.0	N/A	EB
	250	11	125	0.5*	30	5.0	4.0	8.5	AF	AG		
	250	5	125	0.5*	30	5.0	3.0	5.5	EF	EG		
	125	1	-	-	28	1.0*	1.5	-	JR	N/A		
	125	1	-	-	30	1.0	-	6.0	N/A	JB		
	125	1	-	-	30	1.0	3.5	6.0	JF	JG		
	250	7	250	0.25	30	7.0	5.0	-	BD	N/A		

Temperature Switches

Step 3: Switching Element

201AH-**EF**225-U9-C7A-TT

Notes

1. Double switching elements have wire leads except when supplied in housings RN, RT, RB, B3, B4, B5, B6 and V1. Terminal blocks are standard in these housings.
2. Dead band multipliers must be applied to the typical dead band figures given in the specification tables on page 8.
3. Switching element ambient temperature limits:

-65 to 400°F	(-54 to 200°C)	B, Y, W
-65 to 250°F	(-54 to 120°C)	A, E & J
-40 to 167°F	(-40 to 75°C)	AF, AG, EB, EF, EG, JB, JF, JG, JR, KB
-13 to 158°F	(-25 to 70°C)	BD
-65 to 180°F	(-54 to 80°C)	All others

4. The hermetically sealed switching element capsule is UL Listed, CSA Certified and TestSafe Approved as an explosion proof snap switch according to the table with conditions and exceptions specified in Note 3.

Agency	Hazardous Location Conditions	Designator
UL Listed CSA Certified	Class I, Groups A, B C & D; Class II, Groups E, F & G; Divisions 1 & 2	AF, EF, AG, EG, KB, EB, JB, JF, JG, JR
TestSafe Approved	Ex s Zone 1 IIC T4 IP65 Ex tD A21 T105°C IP65	AF, EF, AG, EG, KB, EB

5. Switching Elements W & Y have Elgiloy springs.
6. Certain switching elements can handle greater voltage and/or amperage. Consult the factory should your requirements exceed catalog values. All switching elements above except BD are UL Listed and CSA Certified. The DC current ratings marked with an asterisk (*) are not UL Listed but have been verified by testing and/or experience.
7. Cross reference compatibility chart at the bottom of page 10 to ensure that switching element will fit in housing.

Temperature Switches

Step 4: Ranges

201AH-EF225-U9-C7A-TT

Adjustable Ranges

Designator	Adjustable Range Increasing Temperature		Typical Dead Band		Overrange Temperature		Maximum Process Pressure	
	°F	°C	°F	°C	°F	°C	psi	bar
235	-60 to 60	-51 to 15	1.4	0.8	170	77	2300**	158
225	50 to 200	10 to 93	1.2	0.7	340	171	2300**	158
215	150 to 350	66 to 177	2.2	1.2	500	260	2300**	158
105*	300 to 1000	150 to 540	15	8.3	1100	590	1000	70

* Remote mount only.

** Overage is reduced to 1150 psi when the CV accessory is selected.

Dead Band Considerations

- Dead band values are expressed as typical expected at mid-range using the standard K switching element. When optional switching elements are specified, corresponding dead band multipliers must be applied to the typical dead band values shown in the table whenever optional switching elements other than K, KA or W are used.
- Dead bands are fixed, except when T or H switching elements are used.
- Dead band can be widened by selecting an optional switching element with a multiplier greater than 1.0.
Example: Model 201NN-G225-U9-C7A
Typical standard dead band: 1.2°F
Switching Element G multiplier: 3
Corrected typical dead band: 1.2°(3) = 3.6°F

Switching Element Designators	Multiplier
K, KA, W	1.0
D, E, J, JR, KB, M, Y	1.5
A, AD, B, EF, G	3.0
L, JF, YY	3.5
AF, EE	4.0
BD, EB, JJ	5.0
EG	5.5
AA, BB, GG, JB, JG, KK	6.0
LL	6.5
AG	8.5
T	2.5 to 6.5
H	1.0 to 3.0

Step 5: Diaphragm

201AH-EF225-U9-C7A-TT

U9 Welded Diaphragm System

A metal diaphragm is welded to the pressure port, thereby, eliminating the o-ring.

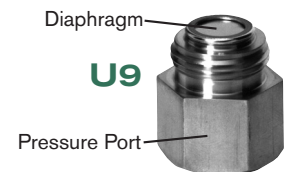

Step 6: Pressure Port

201AH-EF225-U9-C7A-TT

Both direct and remote mount temperature switches have a 1/2" NPT (M) process connection size. See page 17 for dimensions.

Temperature Switches

Step 7: Accessories

201AH-EF225-U9-C7A-TT

Accessory/Option & Description		Designator
Neoprene cover gasket (o-ring) to make L, S and TA explosion-proof housings weathertight.		CG
ATEX/IECEX approved temperature switch. See Agency Listings on page 15 for details.		CL
CSA Certified temperature switch. Available with PP, NN, RB, RN, RT, B3, B6 & V1. Housing has earth (ground) lug. See Agency Listings on page 15 for details.		CS
Canadian Registration Number (CRN) - Process ratings may be affected. Consult the factory for details.		CV
Cemented cover gasket on weathertight housings.		GC
Sealed electrical lead adapter. Provides protection to housing interior, switching element and dry side of pressure sensing assembly from condensate in electrical conduit and corrosive atmospheres. (Protrudes approximate 2" from housing.)		GG
Universal terminal box. Stainless steel. 1/2" NPT(F). ATEX/IECEX Certified Ex db IIC T4, T5 & T6 Gb.		HB*
Universal terminal box. Stainless steel. M20 x 1.5(F). ATEX/IECEX Certified Ex db IIC T4, T5 & T6 Gb.		HBME*
Universal terminal box. Stainless steel. 1/2" NPT(F). FM Approved and CSA Certified Explosion-proof Class I, Groups A, B, C, & D; Class II, Groups E, F, & G, Class III; Divisions 1 & 2 (NEMA 4X IP65)		HT*
Breather Drain	Crouse Hinds ECD-15 for Hazardous Locations Class I, Groups C & D; Class II, Groups E, F & G; on S or SC housings only.	KK
	Sintered metal plug in weathertight housing.	
Terminal block. 6-place compression type standard in B and R series housings. Optional in LC and SC housings. Not available with all housings. Consult the factory.		LL
Multi-Listed temperature switch. ATEX/IECEX, CSA & UL. Available with B3 & B6 housings. See Agency Listings on page 15 for details.		ML
Compliance to NACE Certification MR0175/ISO 15156		NC
INMETRO approved temperature switch. See Agency Listings on page 15 for details.		NM
Pipe (stanchion) mounting kit for (1-1/2 to 2" pipe). Order as a separate line item for UL Listed and CSA Certified temperature switches.		PK
Tag, fiber. Attached with plastic wire to housing. Stamped with customer-specified tagging information.		PP
Powder coat epoxy coating. No coating on stainless steel parts or plated screws. (500 hours-salt spray)		PY
Tag, stainless steel. Attached with stainless steel wire to housing. Stamped with customer-specified tagging information. (2 lines, 18 characters and spaces per line.)		RR
Explosion-proof and weathertight electrical junction box with screw terminals. Aluminum 3/4" NPT(F) top or right conduit connections as required. UL Listed and CSA Certified Class I, Groups A, B, C & D; Class II, Groups E, F & G; Divisions 1 & 2, (AG, AH, BA, L, LC, S, SC & TA housings). Includes cover o-ring for weathertight applications.		TB*
Factory set and potted to prevent future adjustment. This option results in permanent Set point. Available only on housing AC, AG, AH, BG and BH.		TP
Taiwan Safety Mark. Requires IECEX approval, See Agency Listings on page 15 for details.		TS
Oversize stainless steel nameplate or separate stainless steel tag. Permanently attached to housing. Stamped with customer-specified tagging information.		TT
Fungicidal varnish. Covers exterior and interior except working parts.		VV
UL Listed temperature switch available with B3 or B6 housing. See Agency Listings on page 15 for details.		WV
"X" is used as a suffix to the model number for special requirements. Each "X" must be completely identified in the text of the order or inquiry. When more than one "X" is required, use "X" followed by the number of such items. For example, "X3" means three separate otherwise unidentifiable requirements.		X
Epoxy coating. Exterior only. Polyamide epoxy with 316SS pigment. (200 hours-salt spray)		YY
Chained cover with captive screws to conform to former JIC specification.		ZZ

*SPDT switch only if ordered with V2 housing.

Temperature Switches

Step 7: Accessories

201AH-EF225-U9-C7A-TT

Test Certificates

Certificates	D1	D2	C1	C3	C4	C5	C6	C8	B5	B6	B7	A1
Calibration			◆						◆	◆	◆	◆
Inspection Report				◆					◆	◆	◆	
Compliance / Conformance					◆						◆	◆
Dielectric Test						◆			◆			
Insulation Resistance							◆		◆	◆		
Typical Material of Wetted Parts								◆				◆
Certificate of Origin	◆											
Manufacturers's Certification		◆										

Thermowell

Thermowell must be ordered as a separate item

1. Determine insertion length from specification table.
2. Specify thermowell for either direct or remote mounted temperature switches from specifications tables.
3. Specify process connection threading from specification table below.
4. The thermowell must be ordered as a separate item. Thermowells are 316SS (347SS on 275TW-NF100). Consult the SOR representative in your area or the factory for special material.
5. Special sensing bulb diameter and lengths are available. Consult the SOR representative in your area or the factory to discuss your requirements.

Specifications and Dimensions

Thermowell Model Number	Available Sensing Bulb(s)					Mounting	U Insertion Length		A Element Length		B Bore Diameter		Q Insertion Diameter		Process Connection in NPT(M)	Maximum Process Pressure
	201	203	205	207	209		mm	in.	mm	in.	mm	in.	mm	in.		
245 TW-DM 075	◆					Direct	114.3	4.5	152.6	6	10.4	0.41	19.1	0.75	3/4	6200 psi @ 500°F
245 TW-DM 100	◆						1									
245 TW-RM 075		◆	◆			Remote	114.3	4.5	152.6	6	10.4	0.41	19.1	0.75	3/4	
245 TW-RM 100		◆	◆				1									
275 TW-RM 075		◆	◆	◆	◆	Remote	190.5	7.5	228.6	9	9.9	0.39	19.1	0.75	3/4	
275 TW-RM 100		◆	◆	◆	◆		1									
*275 TW-NF 100		◆	◆	◆	◆	Remote	190.5	7.5	228.6	9	16.8	0.66	26.9	1.06	1	4700 psi @ 1000°F

*Model 275TW-NF100 must be used with Range 105.

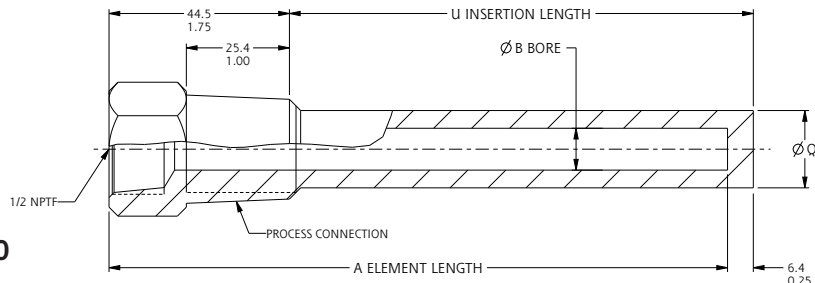

Drawing 0190020

Temperature Switches

Agency Listings

CSA For Hazardous Locations - Class 1, Groups B, C & D; Class II, Groups E, F & G

Bulb	Housing	Switching Element	Range	Diaphragm	Pressure Port Material & Conn. Size	Accessories
ALL	B3, B6	A, AA, AF, AG, B, BB, C, E, EE, EF, EG, G, GG, H, J, JF, JG, JJ, K, KA, KK, L, LL, P, T, W, Y, YY	ALL	ALL	ALL	CS or ML Required. All except CG, GC, GG, HB, HT, KK, LL, ME, TB, TP, TS, ZZ

General Purpose and Weatherproof (CSA Type 4)

ALL	FP (General Purpose)	A, AA, B, BB, C, E, EE, G, GG, H, J, JJ, JL, K, KK, KA, L, LL, T, W, Y, YY	ALL	U9	C7A Standard Others as Required	CS Required. All except GC, LL, TS
	NN (Type 4)	A, AA, B, BB, C, E, EE, G, GG, H, J, JJ, JL, K, KK, KA, L, LL, T, W, Y, YY				
	RN (Type 4) RT (Type 4)	A, AA, AF, AGT, B, BB, C, E, EE, EF, EG, G, GG, GA, H, J, FJ, JG, JJ, JL, K, KK, KA, L, LL, T, W, Y, YY				
	RB (type 4) RH (Type 4)	D, DA, M (Manual reset only)				
	V1 (Type 4)	A, AA, B, BB, C, E, EE, G, GA, H, J, JJ, K, KA, L, LA, T, W, Y				

ATEX/IECEx or INMETRO Ex db IIC T6/T5 Gb

Bulb	Housing	Switching Element	Range	Diaphragm	Pressure Port Material & Conn. Size	Accessories
ALL	B3, B4, B5, B6	A, AA, AF, AG, B, BB, C, E, EE, EF, EG, G, GG, H, J, JF, JG, JJ, JL, K, KA, KK, L, LL, P, N, T, W, Y, YY	ALL	ALL	ALL	CL (for all Hsgs) or ML (for B3/B6 Hsgs) Req'd for ATEX/IECEx NM Required for INMETRO All except CG, GC, GG, HB, HT, KK, LL, ME, TB, TP, ZZ
ALL	BG, BH	AF, AG, EF, EG, JF, JG	ALL	ALL	ALL	BB, HB, HBME, PP, RR, TP, TS, TT, VV, YY NM Required for INMETRO

Ex ia IIC T6...T4 Gb

ALL	RN, RM, RT, RS	J, JJ, JF, JG	ALL	ALL	ALL	NC, PK, TS, X CL Required for ATEX/IECEx NM Required for INMETRO
-----	----------------	---------------	-----	-----	-----	--

UL For Hazardous Locations - Class I, Groups B, C, & D; Class II, Groups E, F, & G

Bulb	Housing	Switching Element	Range	Diaphragm	Pressure Port Material & Conn. Size	Accessories
ALL	B3, B6	A, AA, AF, AG, B, BB, C, E, EE, EF, EG, G, GG, H, J, JF, JG, JJ, K, KA, KK, L, LL, P, T, W, Y, YY	ALL	ALL	ALL	WV or ML Required. All except CG, GC, GG, HB, HT, KK, LL, ME, TB, TP, TS, ZZ

Temperature Switches

Approximate Weights

Housing	Weight (lbs)	(kgs)
AC	1	.5
AG, BG	1.5	.75
AH, BH, NN, N3, N4, PP, P3	2	1
RM, RN	2.5	1.25
BA, N6, RB, V1	3	1.5
RT	3.5	1.75
L, LC, SC	4	2
TA	4.5	2.25
V2	5	2.5
B3, B4	8	3.5
B5, B6	10	4.5

Accessories	Add (lbs)	(kgs)
PK Pipe Kit	1.5	0.7
TB Junction Box with Terminal Block	5	2.25
HB, HBME or HT Universal Terminal Box	2.5	1.1

Actual shipping weights may vary from the charted values because of product material, configuration and packaging requirements.

Temperature Switches

Dimensions

Dimensions in this catalog are for reference only. They may be changed without notice. Contact the factory for certified drawings for a particular model number. All dimensions shown are expressed as millimeters over inches. (Linear = mm/in.)

201 Direct Mount Drawing 0190317

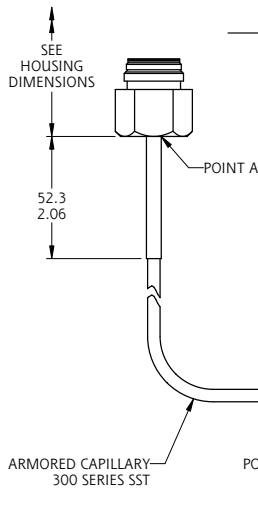
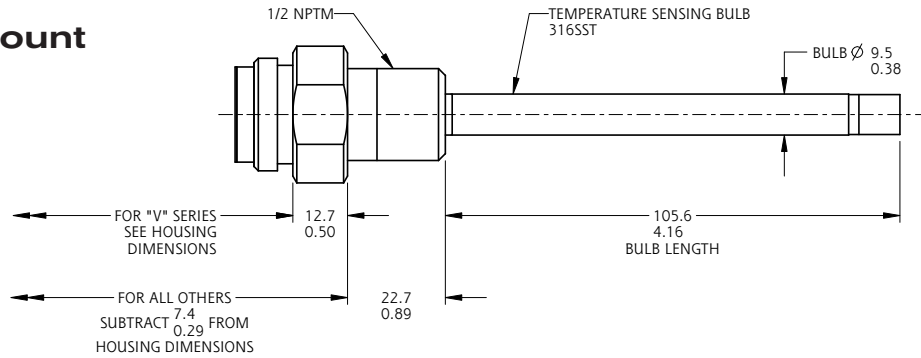

203-209 Remote Mount Drawing 0190318

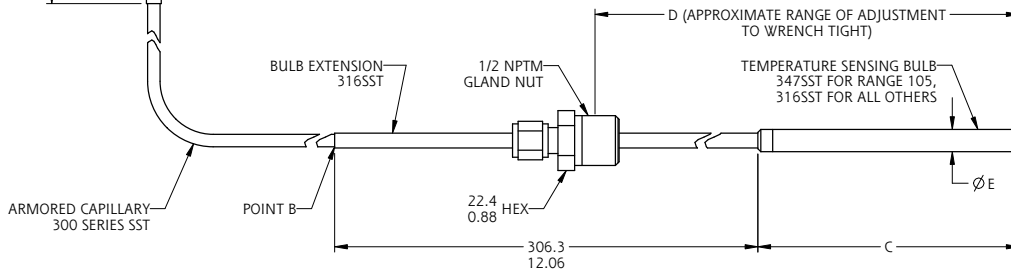

Dimensions

Feature	A-B		C				D				E Diameter			
	All		235, 225, 215*		105		235, 225, 215*		105		235, 225, 215*		105	
Bulb	m	ft.	mm	in.	mm	in.	mm	in.	mm	in.	mm	in.	mm	in.
203	1.8	6.0	112.0	4.41	148.3	5.84	135 to 396	5.3 to 15.6	170 to 433	6.7 to 17.1	9.7	0.38	16.0	0.63
205	3.0	10.0	124.7	4.91	148.3	5.84	147 to 409	5.8 to 16.1	170 to 433	6.7 to 17.1	9.7	0.38	16.0	0.63
207	4.5	15.0	162.8	6.41	148.3	5.84	185 to 447	7.3 to 17.6	170 to 433	6.7 to 17.1	9.7	0.38	16.0	0.63
209	6.0	20.0	194.6	7.66	148.3	5.84	216 to 480	8.5 to 18.9	170 to 433	6.7 to 17.1	9.7	0.38	16.0	0.63

*235 range has same dimensions as the discontinued 135 range.

*225 range has same dimensions as the discontinued 125 range.

*215 range has same dimensions as the discontinued 115 range.

Temperature Switches

Dimensions

Dimensions in this catalog are for reference only. They may be changed without notice. Contact the factory for certified drawings for a particular model number. Dimensions in this catalog are expressed as millimeter over inches (Linear = mm/in.).

Weatherproof-Non-Hazardous Service (NEMA 4, 4X, IP66)

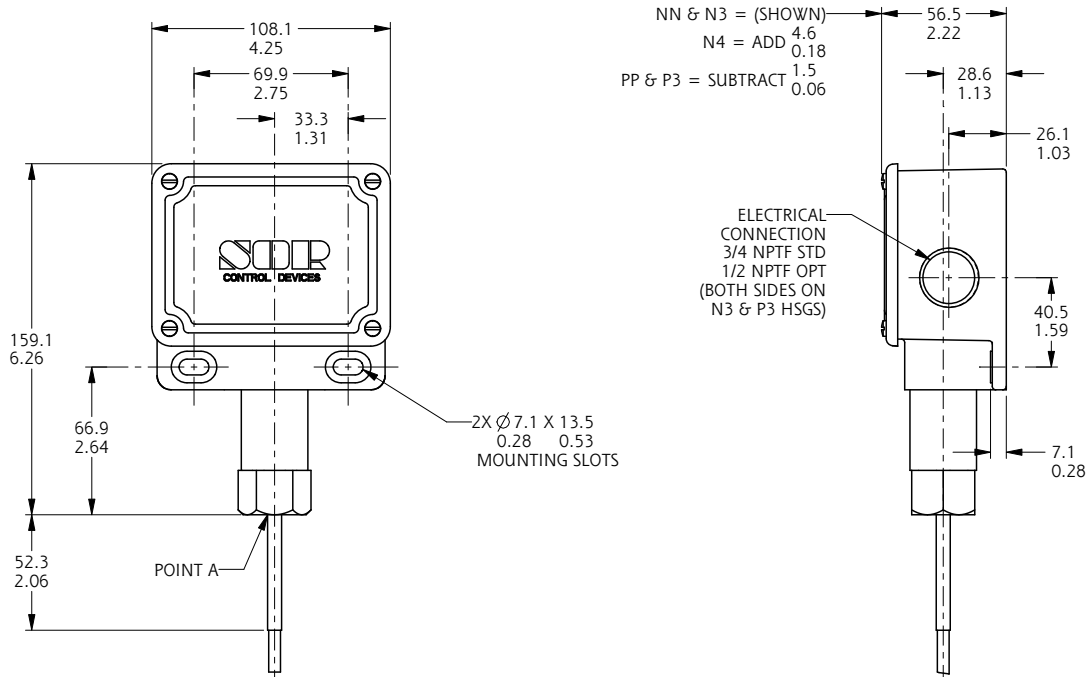

Housing: NN, N3, N4, PP, P3

Drawing 0190157

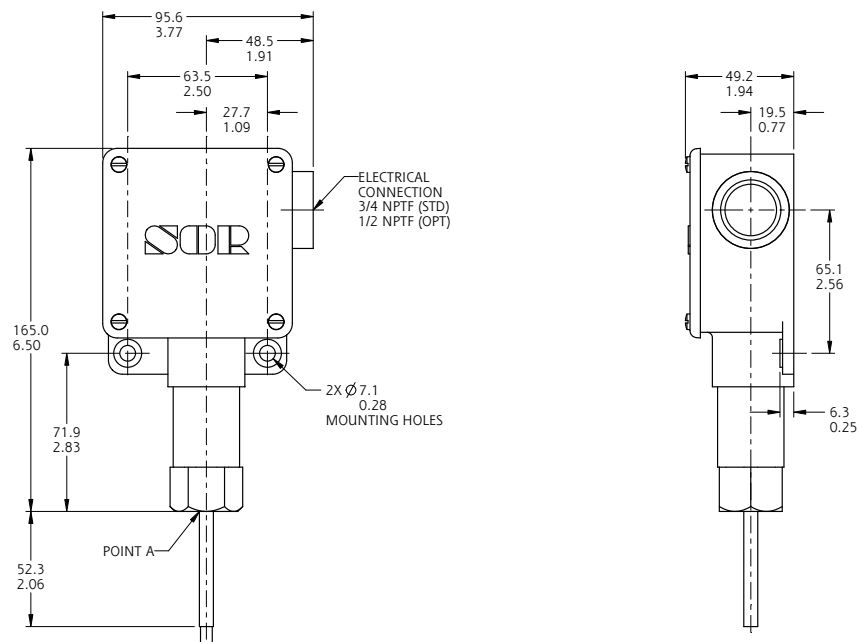

Housing: N6

Drawing 0190173

Temperature Switches

Dimensions

Dimensions in this catalog are for reference only. They may be changed without notice. Contact the factory for certified drawings for a particular model number. Dimensions in this catalog are expressed as millimeter over inches (Linear = mm/in.).

Weatherproof-Non-Hazardous Service (NEMA 4, 4X, IP66)

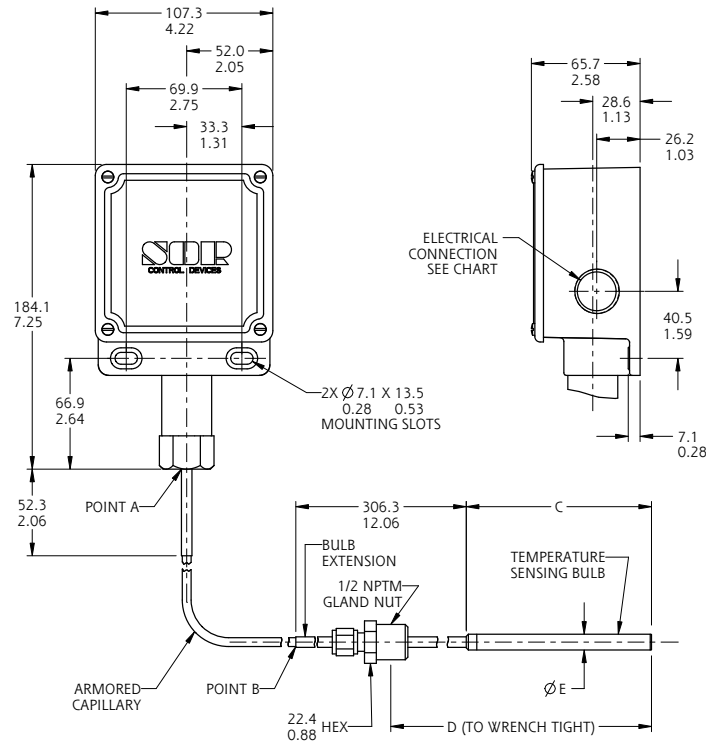

Housing: **RM, RN, RS, RT**

Drawing 0190136

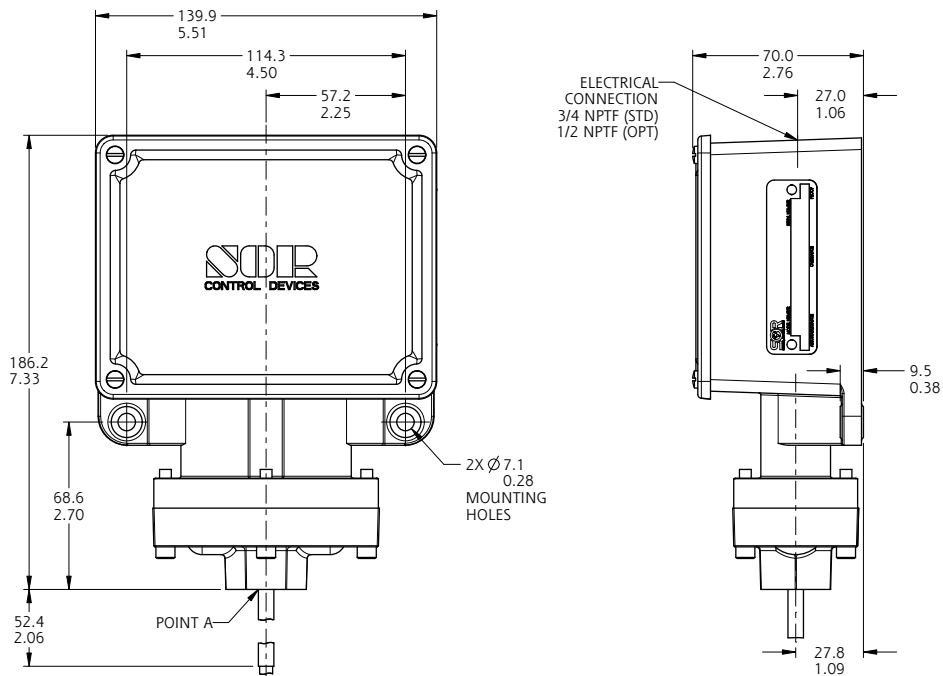

Housing: **V1**

Drawing 0190094

Dimensions in this catalog are for reference only. They may be changed without notice. Contact the factory for certified drawings for a particular model number. Dimensions in this catalog are expressed as millimeter over inches (Linear = mm/in.).

Weatherproof-Non-Hazardous Service (NEMA 4, 4X, IP66)

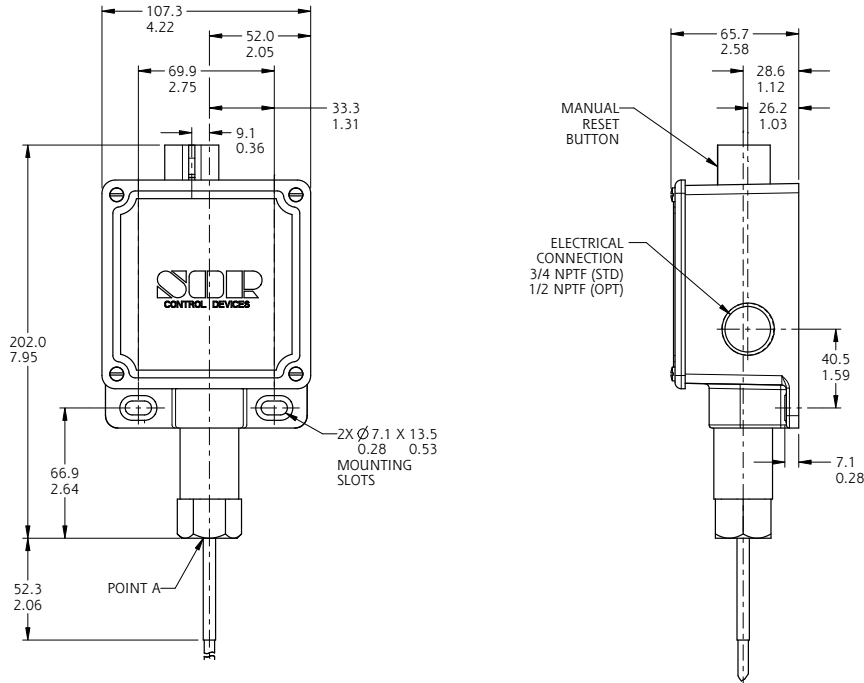

Drawing 0190230

Temperature Switches

Dimensions

Dimensions in this catalog are for reference only. They may be changed without notice. Contact the factory for certified drawings for a particular model number. Dimensions in this catalog are expressed as millimeter over inches (Linear = mm/in.).

Conventional Explosion Proof

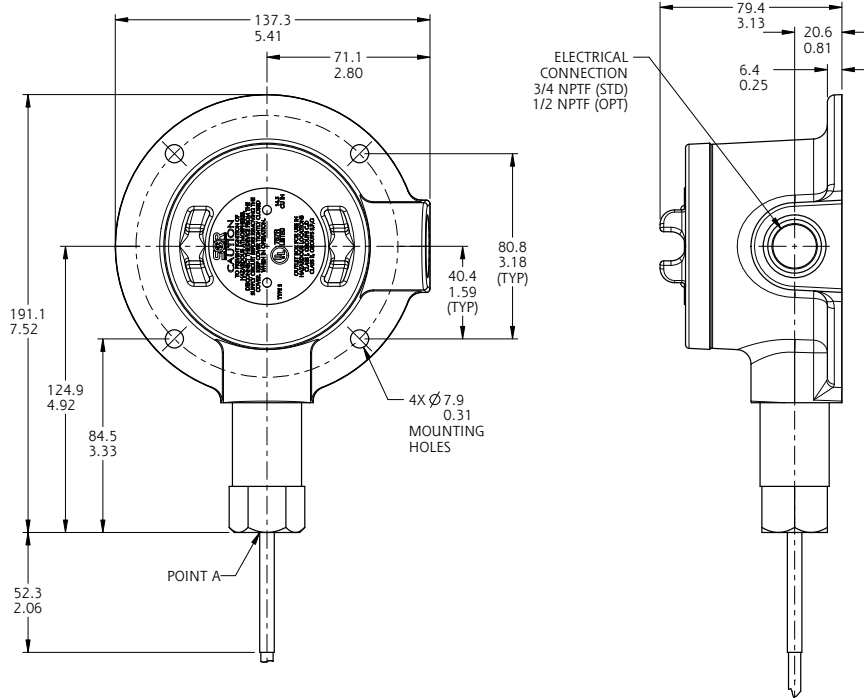

Drawing 0190026

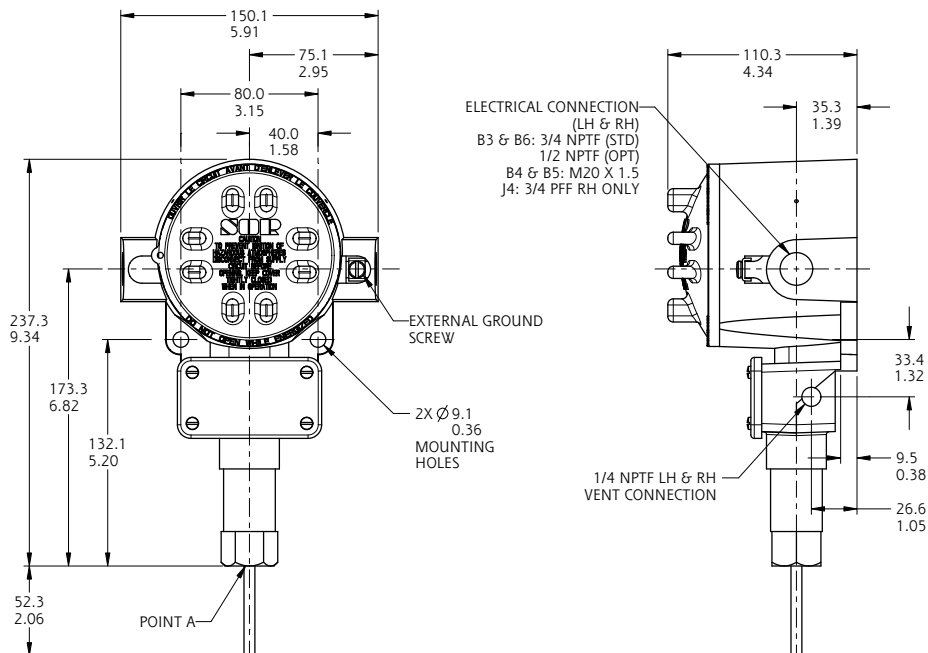

Housing: **B3, B4, B5, B6**

Drawing 0190312

Dimensions in this catalog are for reference only. They may be changed without notice. Contact the factory for certified drawings for a particular model number. Dimensions in this catalog are expressed as millimeter over inches (Linear = mm/in.).

Conventional Explosion Proof

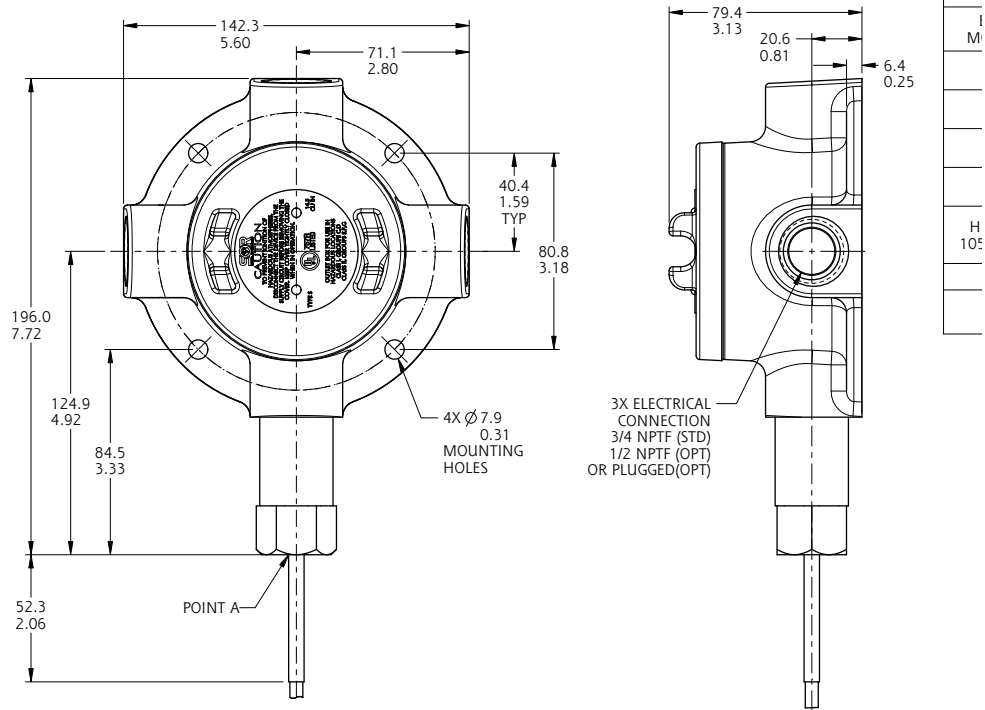

Housing: **S**

Drawing 0190028

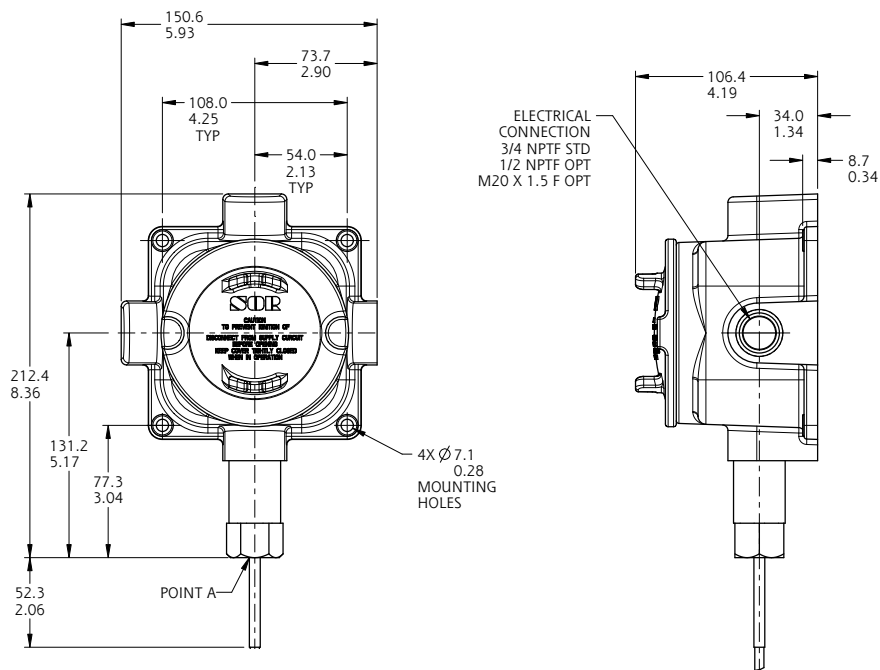

Housing: **LC, SC**

Drawing 0190003

Temperature Switches

Dimensions

Dimensions in this catalog are for reference only. They may be changed without notice. Contact the factory for certified drawings for a particular model number. Dimensions in this catalog are expressed as millimeter over inches (Linear = mm/in.).

Conventional Explosion Proof

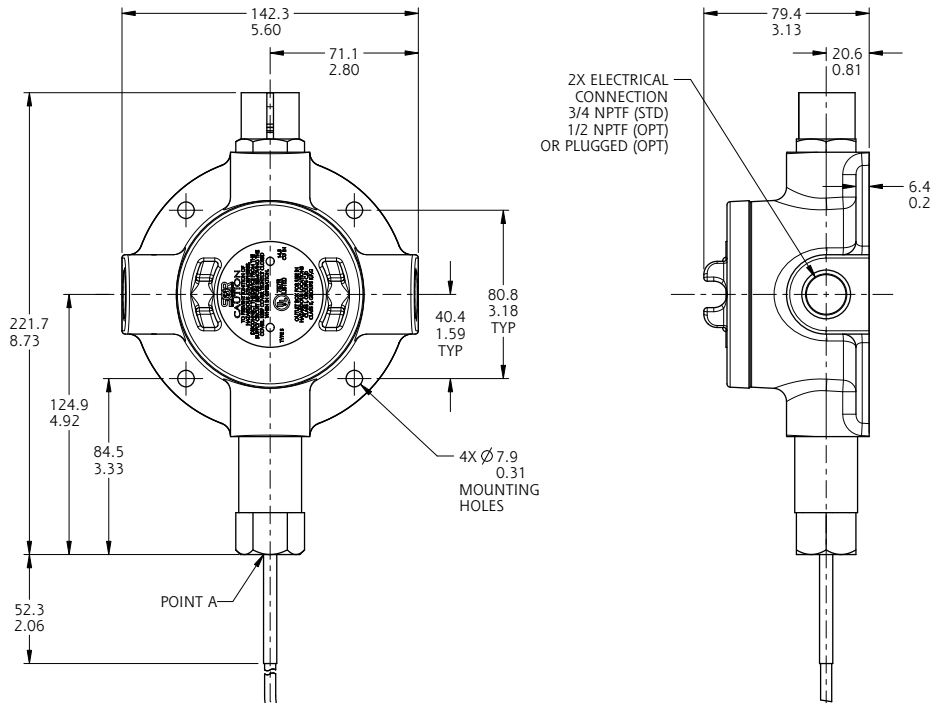

Housing: S-Manual Reset

Drawing 0190308

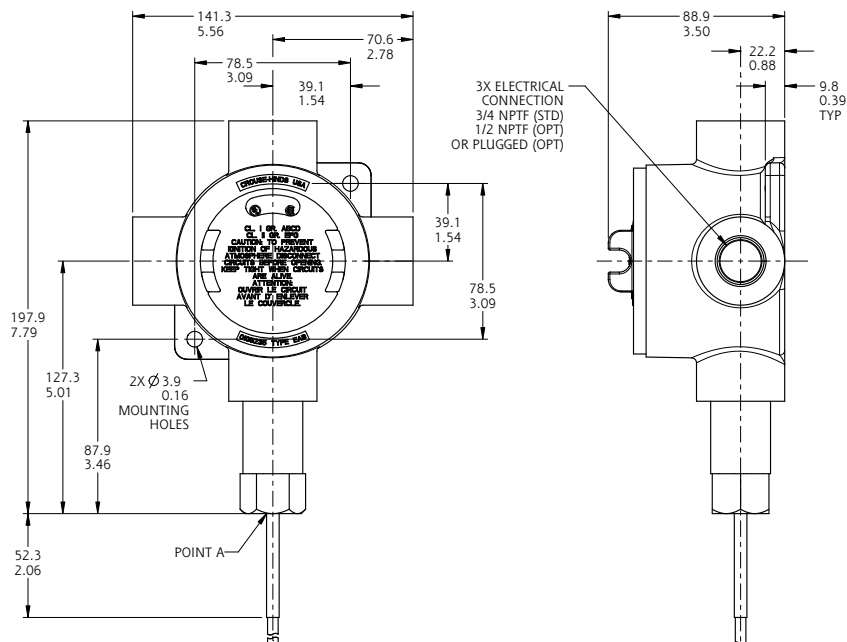

Housing: TA

Drawing 0190184

Dimensions in this catalog are for reference only. They may be changed without notice. Contact the factory for certified drawings for a particular model number. Dimensions in this catalog are expressed as millimeter over inches (Linear = mm/in.).

Hermetically Sealed-Explosion Proof

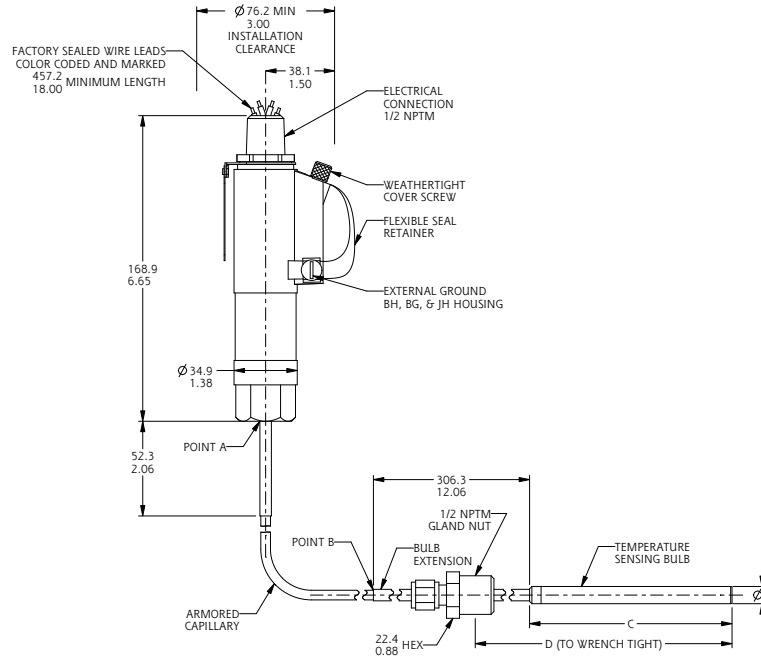

Housing: **AG, AH, BG, BH**

Drawing 0190175

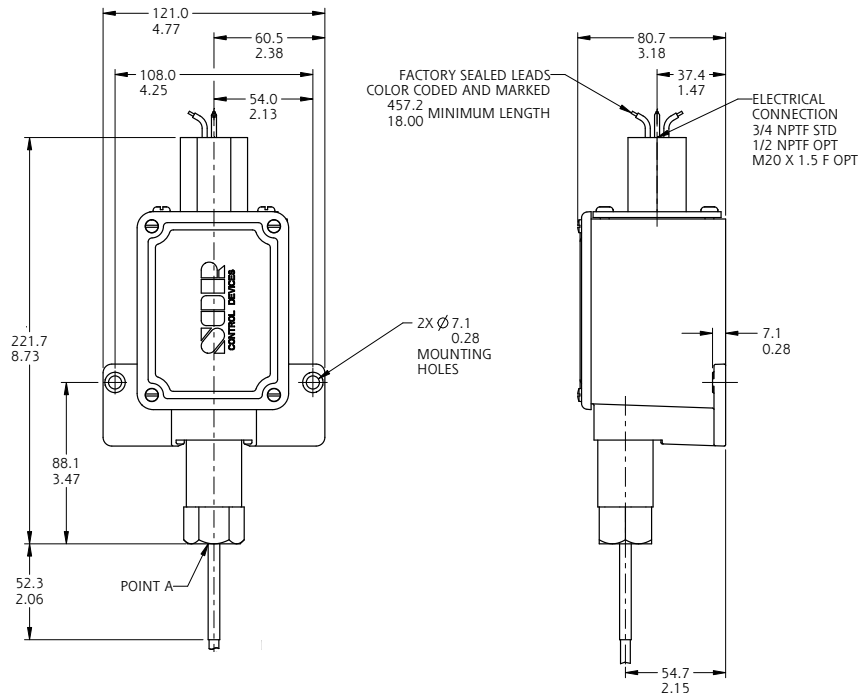

Housing: **BA**

Drawing 0190002

Dimensions in this catalog are for reference only. They may be changed without notice. Contact the factory for certified drawings for a particular model number. Dimensions in this catalog are expressed as millimeter over inches (Linear = mm/in.).

Hermetically Sealed-Explosion Proof

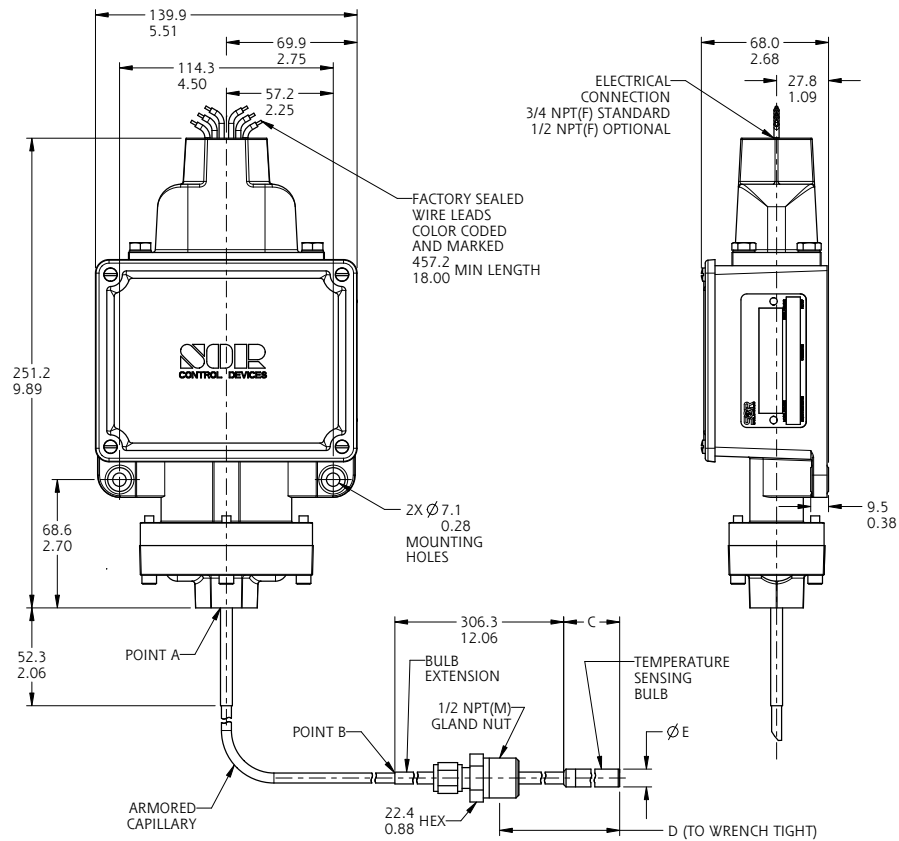

Housing: **V2**

Drawing 0190107

Dimensions in this catalog are for reference only. They may be changed without notice. Contact the factory for certified drawings for a particular model number. Dimensions in this catalog are expressed as millimeter over inches (Linear = mm/in.).

General Purpose (NEMA 1)

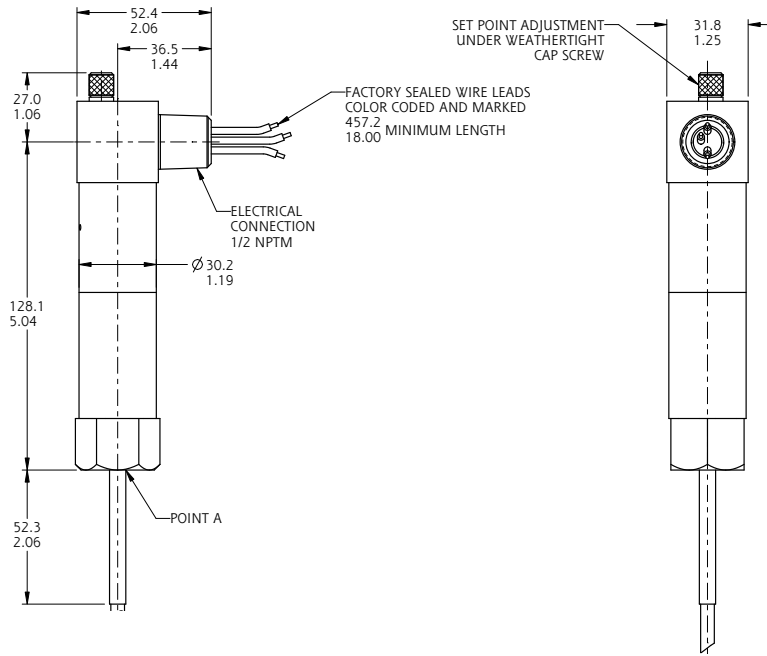

Drawing 0190005



MEASUREMENT AND CONTROL

Lenexa, KS USA | 913-888-2630 | Fax 913-888-0767 | SORInc.com

REGIONAL OFFICES

China

SOR China | Beijing, China | china@SORInc.com
+86 10 5820 8767 | Fax +86 10 5820 8770

Middle East

SOR Measurement & Control Equipment Trading DMCC | Dubai, UAE
middleeast@SORInc.com | +971 4 278-9632 | Fax +1 913 312 3596